

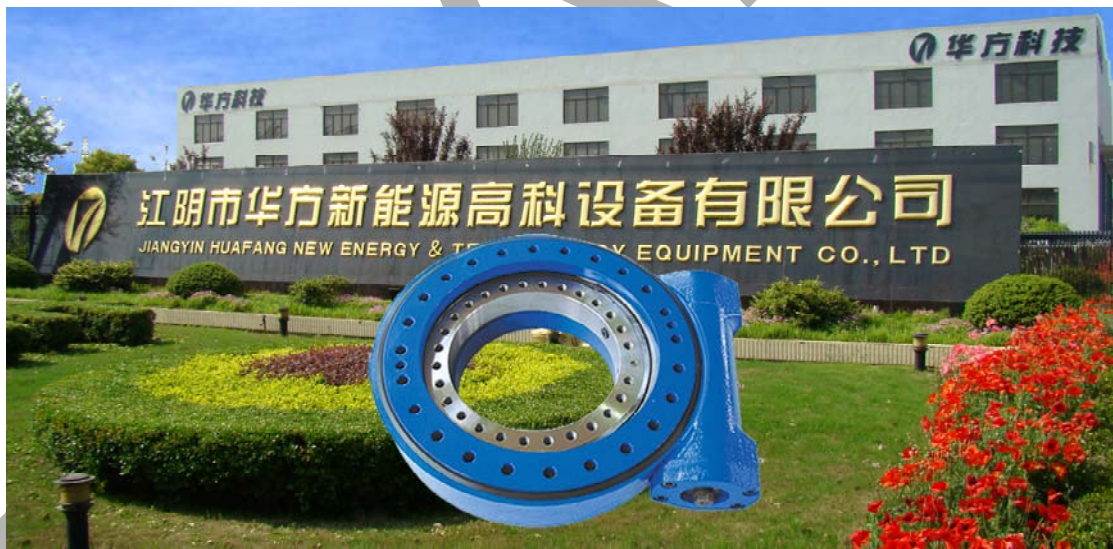

JIANGYIN HUAUFANG NEW ENERGY HI-TECH EQUIPMENT CO., LTD

SLEWING DRIVE MANUAL



Please Read all instructions and manuals carefully before installation

Revision: E

www.h-fang.com.cn

General:

- The purchaser is responsible for protective measures and installation of all the equipment.
- Please read the manual carefully before installation, only complying with the manual, the working characteristic can be ensured.
- The following instructions provide the information needed for correct installation and maintenance of the slew drives.
- All the work steps listed below are to be executed by suitably qualified personnel.
- Please do not hesitate to contact our technical department for any further assistance.
- The latest version is published on our homepage and can be downloaded from there www.h-fang.com.cn Please always check that you are working with the latest revision!

Service Contact:

JIANGYIN HUAFANG NEW ENERGY HI-TECH EQUIPMENT CO., LTD

No.20 Yungu Road, Changshou,

Village, Zhouzhuang Town

JiangYin, 214400 Jiangsu, China

Ph: +86-510-86366206

Fax: +86-510-86366200

Http://www.h-fang.com.cn

Email: sales@h-fang.com.cn

The Structure Sketch of Slewing Drive

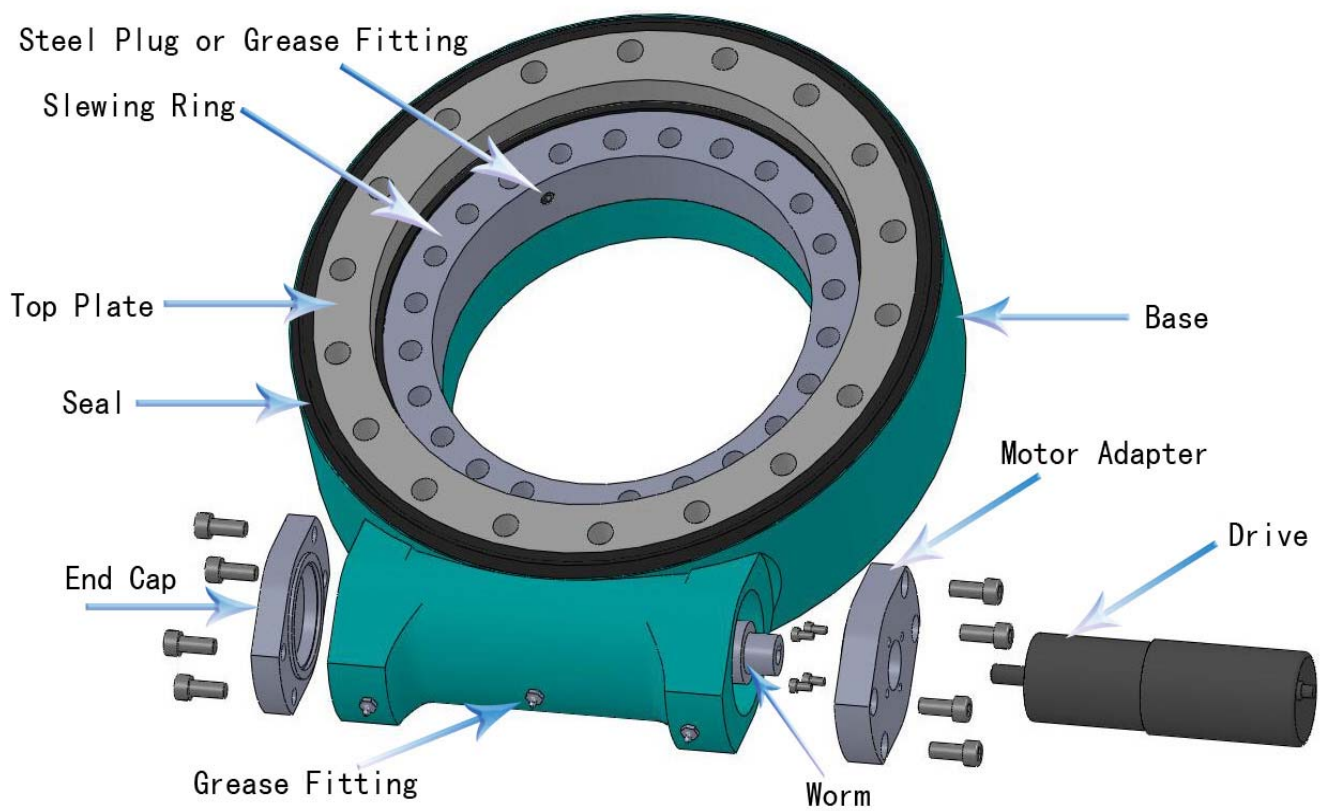

Friendship Recommendation:

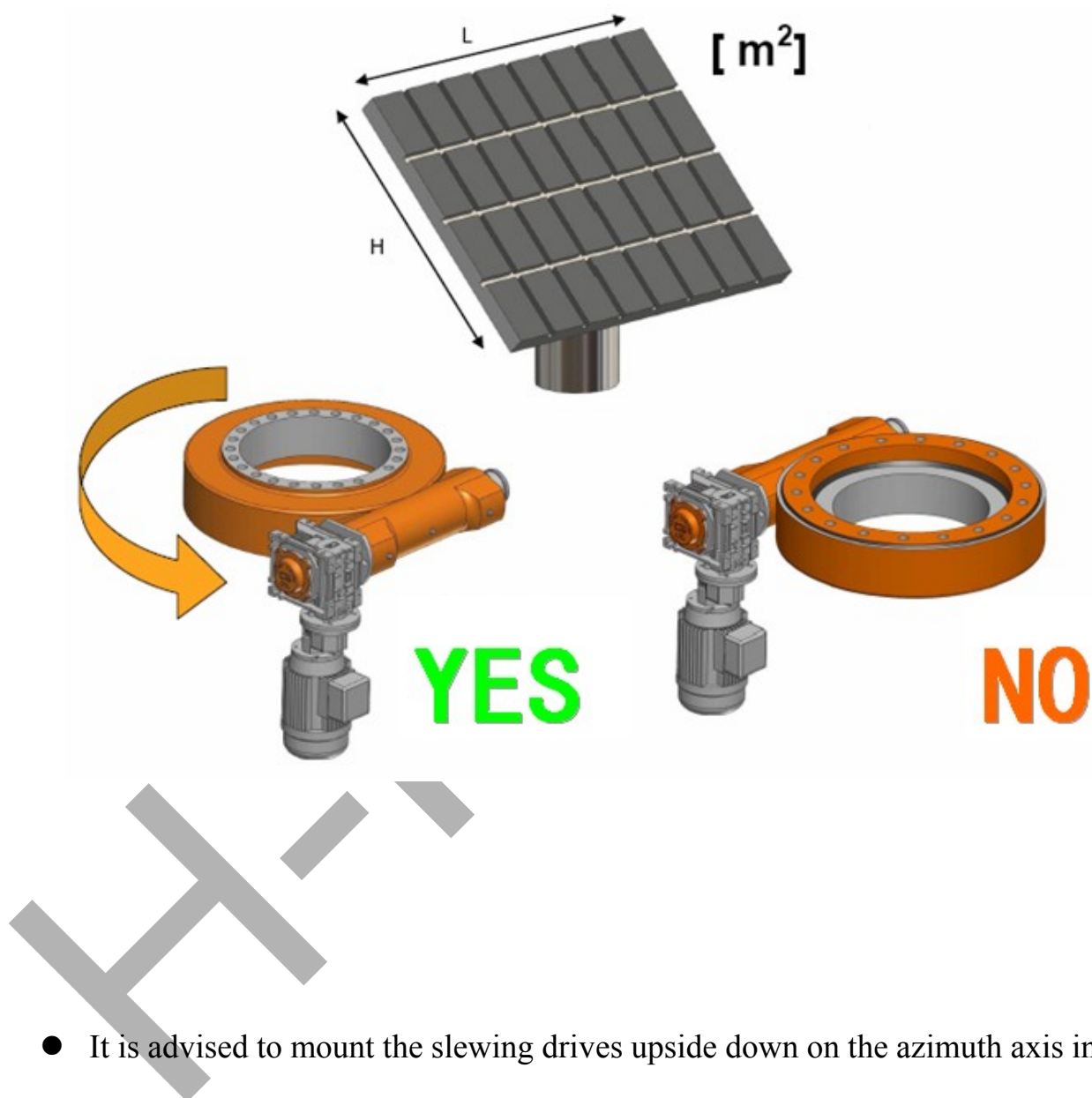

- It is advised to mount the slewing drives upside down on the azimuth axis in solar applications for better protection and add protection for the elevation axis.
- For other applications, the mounting directions shall be based on the evaluation of the protection level and it shall be better for better protection.

Vertical installation of slewing drive for solar application

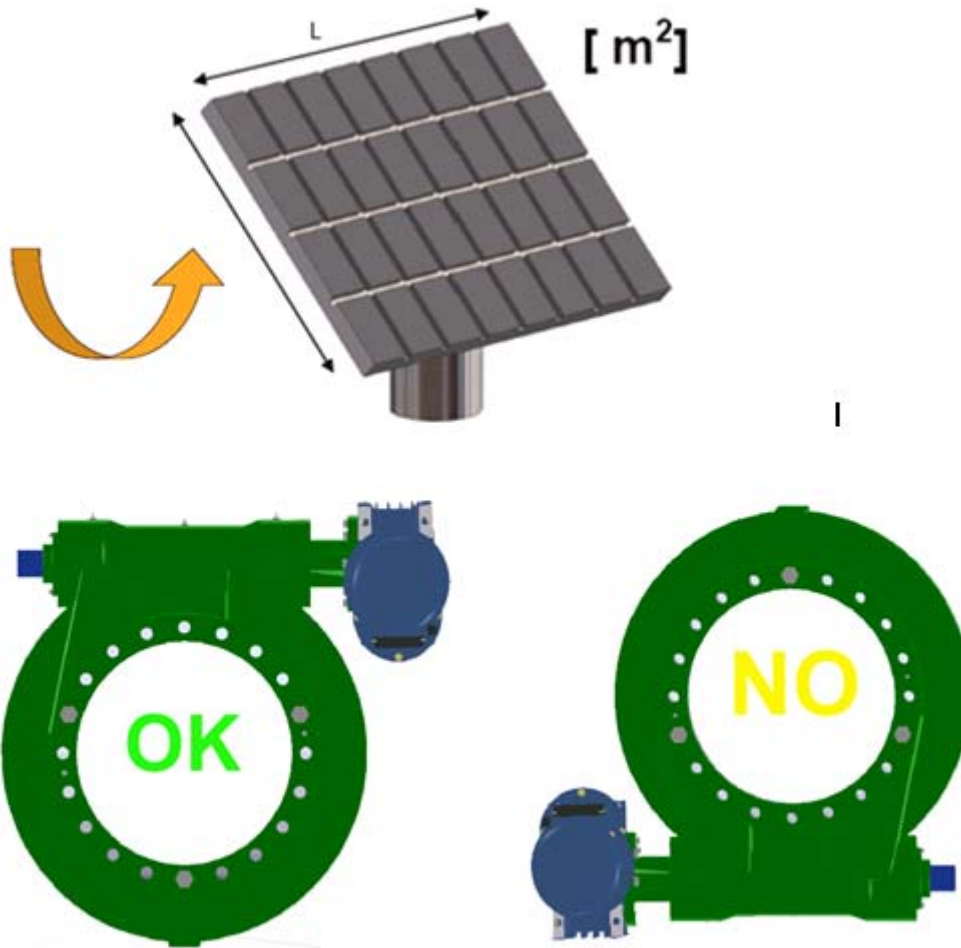

- It is advised to mount the slewing drives referring to attached drawing upside in solar applications for better protection.
- For other applications, the mounting directions shall be based on the evaluation of the protection level and it shall be better for better protection.

Content

1. Transport、 Handling & Storage Provisions	1
1.1 Transport & Handling	1
1.2 Storage.....	1
2. Installation & Maintenance	1
2.1 Preparation.....	1
2.2 Cleaning.....	1
2.3 Shoulder bolts and Shipping bolts.....	1
2.4 Permissible horizontal Deviation.....	2
2.5 Permissible Flatness Deviation.....	2
2.6 Mounting Bolts	2
2.7 Installation of slewing drive	3
2.8 Maintenance、 Checks & Lubrication.....	4
3. Drive & Control	6
3.1 Hydraulic motor.....	6
3.2 Electric motor.....	7
3.3 Encoder.....	7

Installation & Maintenance Provision

Notice:

The following text includes special notices and procedures that shall be observed.

1. Transport、 Handling & Storage Provisions

1.1 Please keep the slewing drive in prescribed position and avoid any collision.

Wear work gloves and take it carefully when handling the slewing drives.

Use the holes of the rings in the slewing drives to fix bolts for safe hoisting, handling and placement.

1.2 Store only in a prescribed position and in closed rooms, keep it away from getting wet, the surface corrosion protection holds for approx. 5 months in closed packaging, longer period storage requires special protective measures.

2. Installation & maintenance

2.1 Preparation

- Check the slewing drive for physical damage.
- Clean the slewing drive and the mounting structure, see *Cleaning*.
- Remove extraneous materials from supporting surfaces.

2.2 Cleaning

- Clean the exterior of the mounting surfaces using cold solvent (e.g. diesel oil) that will not damage the rubber seals.
- Applicable provisions for cleaning media are observed (e.g. manufacturer provisions, protection of workers, environment protection).

2.3 Shoulder bolts & Shipping bolts

When mounting the Slewing drive, the shoulder bolts can not be removed .The shipping bolts should be removed.

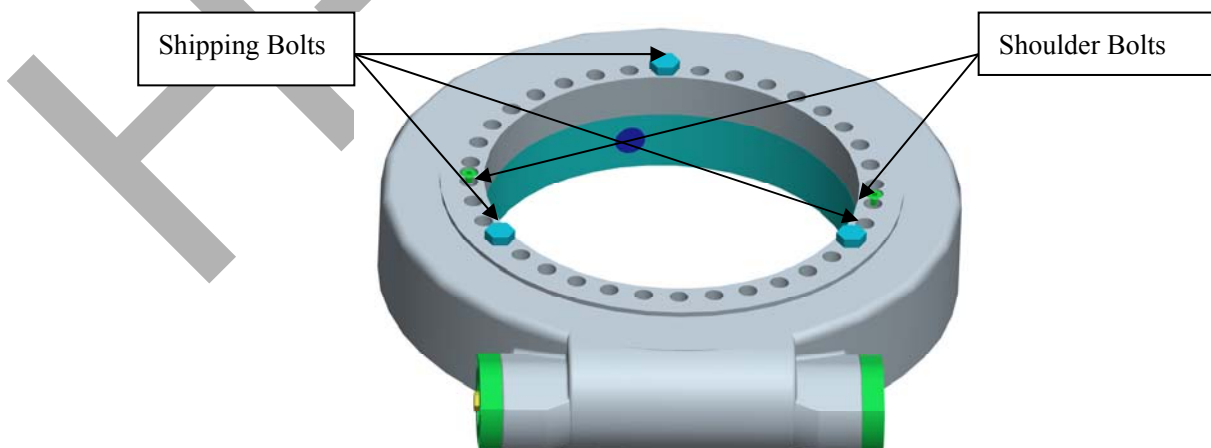

2.4 Permissible horizontal Deviation of the mounting surface

Table 1

Size of Slewing Drive		3 "	5 "	7 "	9 "	12 "	14 "	17 "	21 "	25 "
Permissible perpendicularity deviation in length	[mm]	0.07	0.09	0.11	0.16	0.23	0.26	0.32	0.42	0.49
Permissible perpendicularity deviation in angle dimension	degree	0.09	0.09	0.09	0.09	0.09	0.09	0.09	0.09	0.09

2.5 Permissible Flatness Deviation of the mounting surface

Table 2

Size of Slewing Drive		3 "	5 "	7 "	9 "	12 "	14 "	17 "	21 "	25 "
Flatness deviation	[mm]	0.04	0.1	0.1	0.12	0.15	0.15	0.15	0.2	0.2

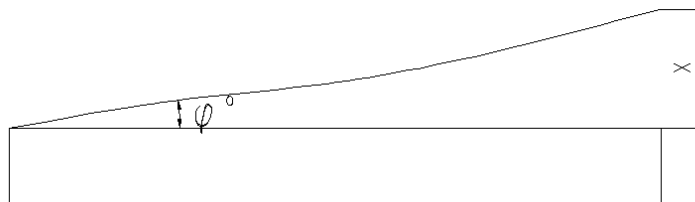

φ - Angle Deviation
 x - Distance perpendicular Deviation

The form must resemble a sine curve that gradually rises and falls.

2.6 Mounting Bolts

As the gearbox manufacturer, we do not supply warrant or recommend the mounting fasteners used.

- Please take great care in specifying this item which will attach our product to yours.
- Prescribed sizes, number and quality grades shall be used.
- Grip ratio (grip length to diameter of bolt) shall be observed, from minimum ≥ 2 to maximum ≤ 10 .

Slewing drive function, lifespan, and durability of the bolt connection are affected in case of non-compliance.

- Use flat washers of appropriate size and strength choice of tightening torques so that the permissible interfacial pressure is not exceeded.
- When mounting the Slewing drive, please remove the shipment bolts.

2.6.1 Tightening Torques

- Use of split rings, split washers, etc. not permissible.
- Tightening torques and initial preloads for mounting bolts.

Information of this table is for guidance only.

Table 3

Metric Bolts		
Mounting bolt Dimension	Tightening torque (Nm)	
	Class 10.9	Class 12.9
M8	33±3	45±6
M10	72±6	90±10
M12	120±10	150±20
M16	305±25	380±50
M18	415±35	521±70
M20	600±50	750±100

2.7 Installation of Slewing Drive

- Clean the mounting structure, e.g. from welding, galvanizing, residues, dirt, etc.
- Lift the slewing drive with eye bolts.
- The slewing drive shall be mounted in unloaded condition.

2.7.1 The following procedure shall be followed in order to avoid deviations between bolt tightening forces.

- Apply thread lock liquid to threads.
- Preload the bolts including washers, if required, crosswise. See the general pattern in sketch below of how bolts get torqued in crosswise sequence. Start with either inner or outer ring. The crosswise torque of all bolts to 30% of tightening torque is first applied. Then repeat crosswise torque to 50% of tightening torque. Finally crosswise torque to 100% of the tightening torque.

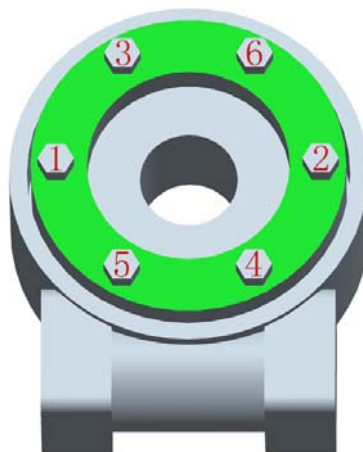

- First completely torque inner or outer ring, then do the other ring.
- Once the screw is tightened, please make a permanent mark on the position of the screw head to that of the stationary structure. This will be used later during inspection to be sure the screw head has not unwound.

2.7.2 Paint Repair

During the installation of slewing drive, The surface paint will be collision damage inevitably. So after the whole system installation. The slewing drive need to be paint repair to improve the rust prevention and anticorrosion performance of slewing drive.

2.8 Maintenance、Checks & Lubrication

2.8.1 Mounting Bolts and Checks

To compensate for possible settling, it is necessary to retighten the bolts to the prescribed torque .This shall be done after no more than 100 hours of operation and without external load applied to the bolt connection. This inspection shall be repeated annually.

The inspection frequency may be reduced under special operating conditions. In case of loose bolts, replace all bolts and washers with new ones.

2.8.2 Lubrication and Mounting Bolts

There are three places which need to be lubricated, they are slewing ring raceway, worm thread and taper roller bearings. Slewing drives are supplied fully lubricated.

A suitable grease type for normal cases is shown on **table 4**

Table 4

Parts needed to be lubricated	Roller Bearing Ring raceway Worm Gear Thread
Recommended Grease Product name	7014-1 High Temp. by China Petroleum & Chemical Corp.
Applicable temp. range in °C	-40 ~+200
Color	White
Four-ball test	3500 N welding load
Viscosity (-40 °C, 10 s-1) Pas	653
Dropping Point °C	316
Penetration, Worked 0.1 mm	67

NOTE: This kind of ecological friendly grease is harmless to human and circumstance

Foreign products having equal performance

Performance of this product is equal to that of as follows:

Changcheng brand	Japan	Germany	America
YP7014-1	丸善 WR-3	ISOFLEX NBU15	DOW CORRING-44、MOBILITMP SHC 100、MOBILITMP SHC 32、CALTEX UNITEMP GREASE 550

Table 5

Parts needed to be lubricated	Quantity of grease-filled (unit: g)								
	3 "	5 "	7 "	9 "	12 "	14 "	17 "	21 "	25 "
Ring raceway	/	10-15	15-20	30-35	45-50	55-60	70-75	120-130	140-150
Worm Gear Thread	330-350	50-60	55-65	90-100	100-110	100-110	110-120	130-140	130-140
Taper Bearing	7±0.5	7±0.5	7±0.5	10±0.5	10±0.5	10±0.5	10±0.5	10±0.5	10±0.5

Manufacturer provisions about handling the respective lubricants must be observed.

- While rotating the slewing drive, inject grease into all the cleaned grease nipples consecutively ,the quantity of grease-filled need to according to **Table 5**

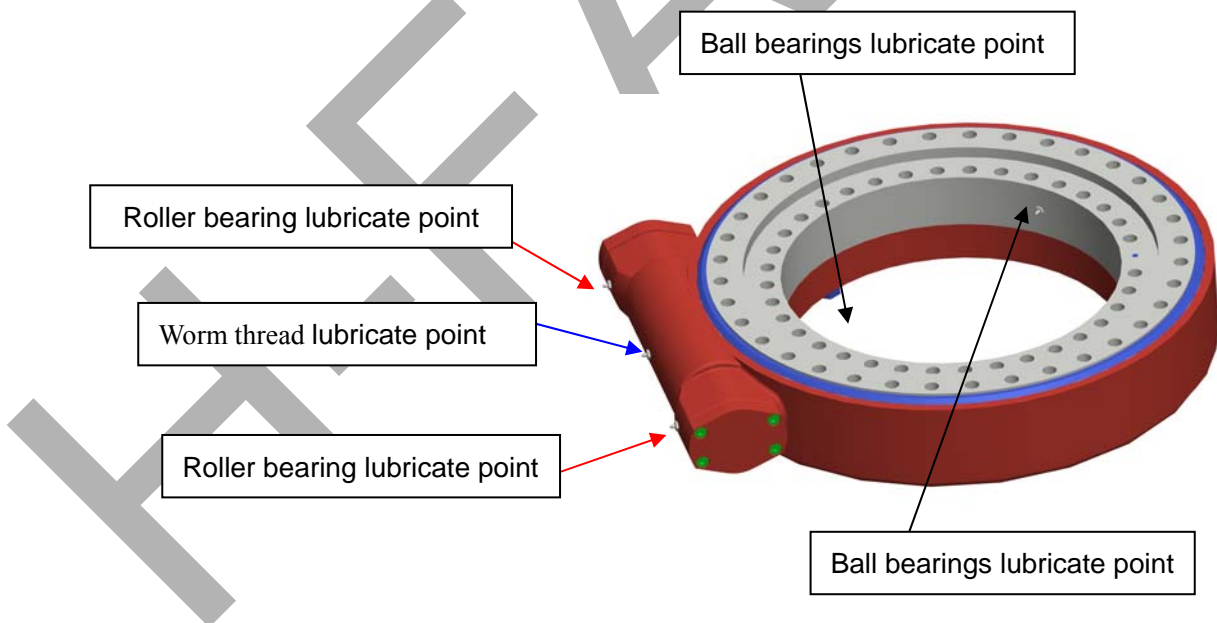

Recommended re-lubrication every 3 years by filling each cavity completely with new grease.

Table 6

Work conditions	Grease-filled slewing drive lubrication intervals
Dry and clean workshop, industrial positioners (turntables/robots, etc.)	Every 500 hours of operation or once every 1 year.
Difficult conditions in open grounds (crane/ bulldozer, etc.) wind turbine, solar, man-lift	once every year
Aggressive climatic conditions sea/desert/Arctic climate/very dirty surrounding/more than 70 continuous operating hours per week	Every 150 hours of operation or once Every 4 months
Extreme conditions (tunneling machines, steel mills, oil field)	every 50 operating hours, at least, however every 2 months

- The specified values are valid for the following conditions
 - Operating temperature on slewing drive -30 °C~ +60 °C
 - Driver rotational speed < 2 rpm (maximum speed varies depending on torque load applied during the same time)
 - Low to medium loads(**Table 7**)

Table 7

Size	3"	5"	7"	9"	12"	14"	17"	21"	25"
Rated torque (KN • m)	0.2	0.3	1	8	9	11	14	17	20

- The **Table 7** can never replace values established through experience; the most frequent cause of failure of slewing drives is insufficient lubrication.
- Cleaning a slewing drive with steam jet or high-pressure cleaner is not permissible.

3 Drive & Control

3.1 Hydraulic motor

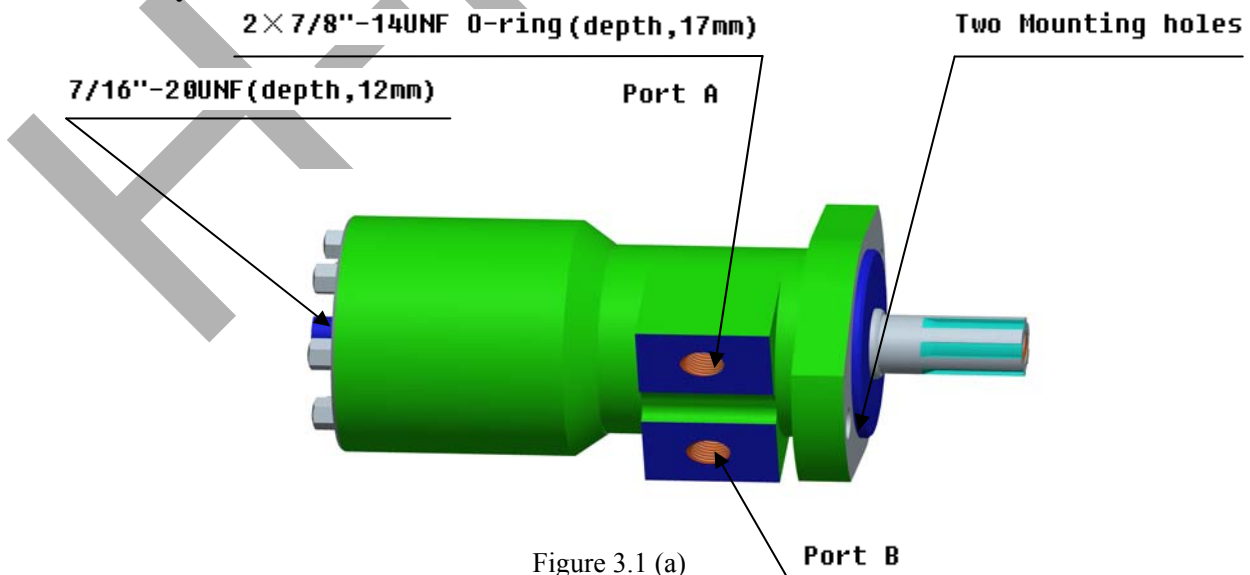

Cleaning mounting surface see *cleaning*

Check mounting position

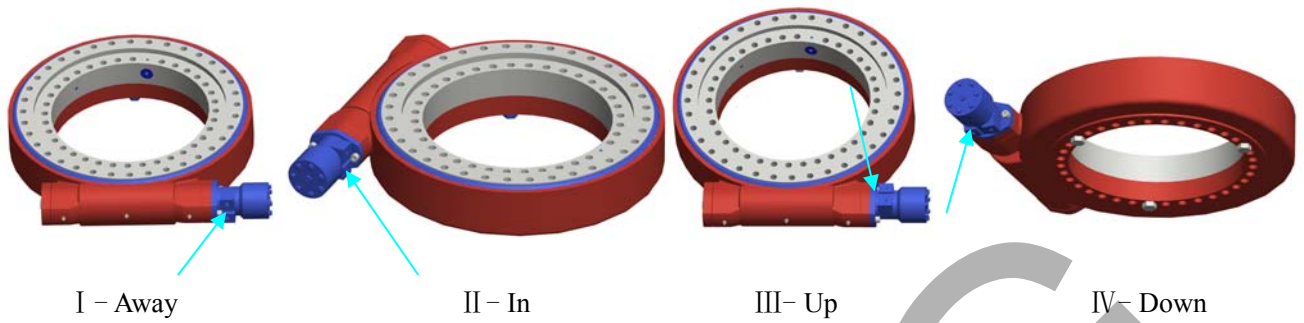

Check motor rotation

See Figure 3.1(a), from output shaft, input Port A and output Port B, Rotation is **CW**; to the contrary, input Port B and output Port A, Rotation is **CCW**.

Check mounting bolts tightening torque see **Table 3**

Connect Hydraulic supply to motor.

Rotate the motor under no load, confirm it rotates smoothly. Once it does not rotate, please check the oil system or current system; please check the joint, Slewing drive & worm etc; Checking there is enough grease in running location.

After the test under no load successfully, then add the rated load.



For other type Hydraulic motor, need to read the specification attached with product!

3.2 Electric motor

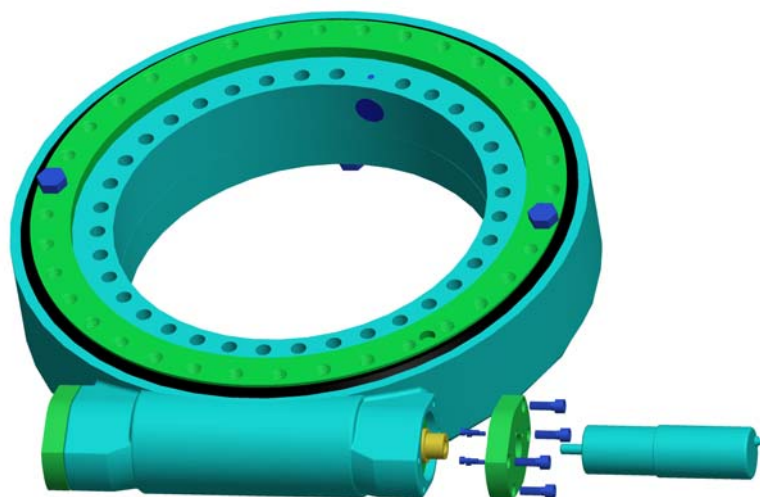

Figure 3.2

For standard 24VDC motor

Cleaning mounting surface see *cleaning*

Join the adapter and tightening screws to the motor;

Put on the motor and tightening screws to the base;

Connect the DC power to the motor, check the rotation. If not in desired direction of rotation, exchange the LINE (L) and NEUTRAL (N).

Rotate the motor under no load, confirm it rotates smoothly. Once it does not rotate, please check the current system; please check the joint 、 Slewing drive & worm etc; Checking there is enough grease in running location.

After the test under no load successfully, then add the rated load.



For other motor, such as 110VDC motor, brushless DC motor, AC motor etc. need to read the specification attached with product!

3.3 Hall Sensor

3.3.1 Standard Magnetic pulse generator

Model		M2-V	M2-N
Output type		voltage output	Open Collector(NPN)
Pull-up resistor		yes	no
Output signal		2 square wave signals, phase quadrate:	
Impulses per revolution	ppr	2,channels A and B	
Operating voltage	VDC	$U_N=12 (5 \dots 24)$	
Operating current	mA	max. 12 ($U=12V$)	
Deviation of pulse width		max. 15°	
Deviation of phase shift		max. 15°	
Output voltage(low level)	VDC	max. 0.4 (20mA)	
Operating temperature	°C	-40 ... +85	

Connection: For DC motor

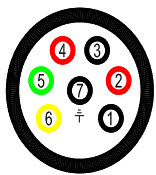

Electric Connection:

Pin 1: Motor, 0V (MOTOR INPUT), (Black thick wire inside)
 Pin 2: Motor, +24V (MOTOR INPUT), (Red thick wire inside)
 Pin 3: Hall, 0V (HALL INPUT), (Black thin wire inside)
 Pin 4: Hall, +12V(5-24) (HALL INPUT), (Red thin wire inside)
 Pin 5: Hall, Signal A (HALL OUTPUT,square wave signal)(Green thin wire inside)
 Pin 6: Hall, Signal B (HALL OUTPUT,square wave signal)(Yellow thin wire inside)
 Pin 7: GROUND (G)

3.3.2 Hall Sensor circuit diagram

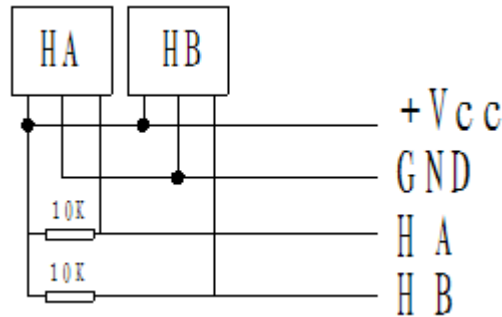

3.3.3 Output Waveform Mechanical Rotation Angel

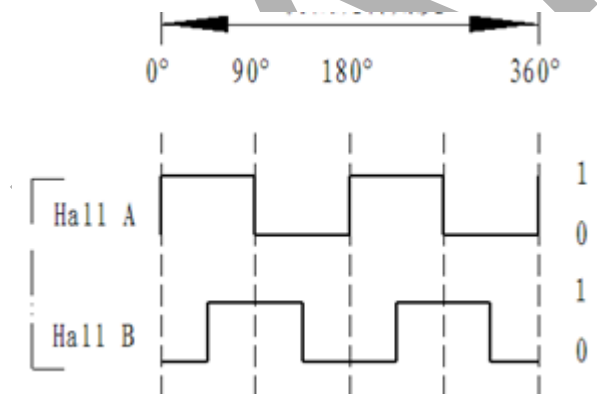

3.3.4 Note for Hall Sensor operation

- Please apply 5-24 V DC power to the Hall Sensor, and the working current should be no more than 50mA.
- Connect the DC power in the right way; the poles (+24V; 0V) should not be reverse. Otherwise, the hall sensor will be damaged.
- Please do not apply the DC motor's power to the Hall Sensor directly.
- Please apply anti-static measures to protect the Hall Sensor.
- The Hall Sensor cable should not twine other cables to avoid signal interference

3.3.2 Photoelectric Encoder

Incremental encoder

Resolution	100/360/500/600/1000/1024
Output signal	3 (A, B, Z)
Operating voltage	5/28 VDC
Electric characteristic	Push-pull/NPN OC/long drive
Transmission frequency	115 kHz
Rotate speed	Max6000 rpm
IP grade	IP54
Cable output	2m radial output
Crust material	plastic
Shaft size	6x15mm stainless steel
Operating temperature	-10...70 degree
Bearing	2XPBQ 626 ZZ
Polarity protection	Yes

Connection:

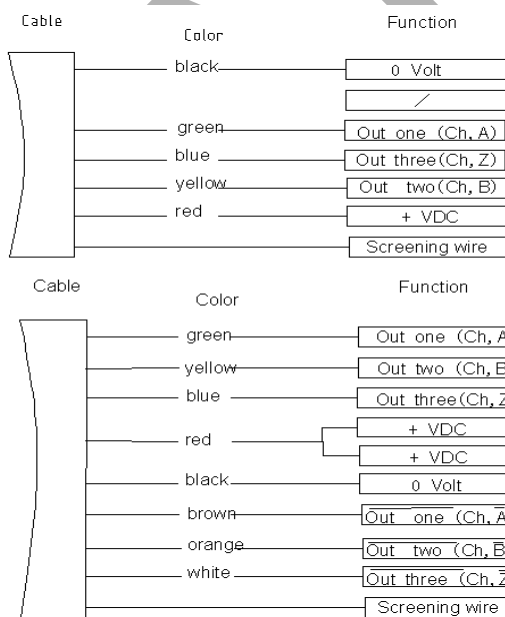

For other encoder, such as incremental encoder and etc. need to read the specification attached with product.

H-FANG accepts no liability for:



- Failure to pass the manual to the related third party
- Non-compliance with Installation and Maintenance Instructions
- Any omissions or errors in following the manual